

Forma 5

SEAT MODULES, STOOLS AND
CENTRE TABLES

TECHNICAL FEATURES

LET'S SIT



STOOLS

Seat

Injected polyurethane foam, upholstered
Inner board, 18 mm thick



Support
With or without glides

Legs
ø 11 mm rod steel

DIMENSIONS

STOOLS	Hight stool	Medium stool	Low stool
Height	65,2 cm	45,2 cm	38,2 cm
Diameter	37,3 cm	37,3 cm	54,4 cm
Fabric meter lineals	0,6 m	0,6 m	0,79 m
Weight	5,77 kg	5,09 kg	7,72 kg

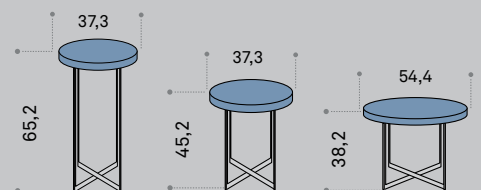

CENTRE TABLES

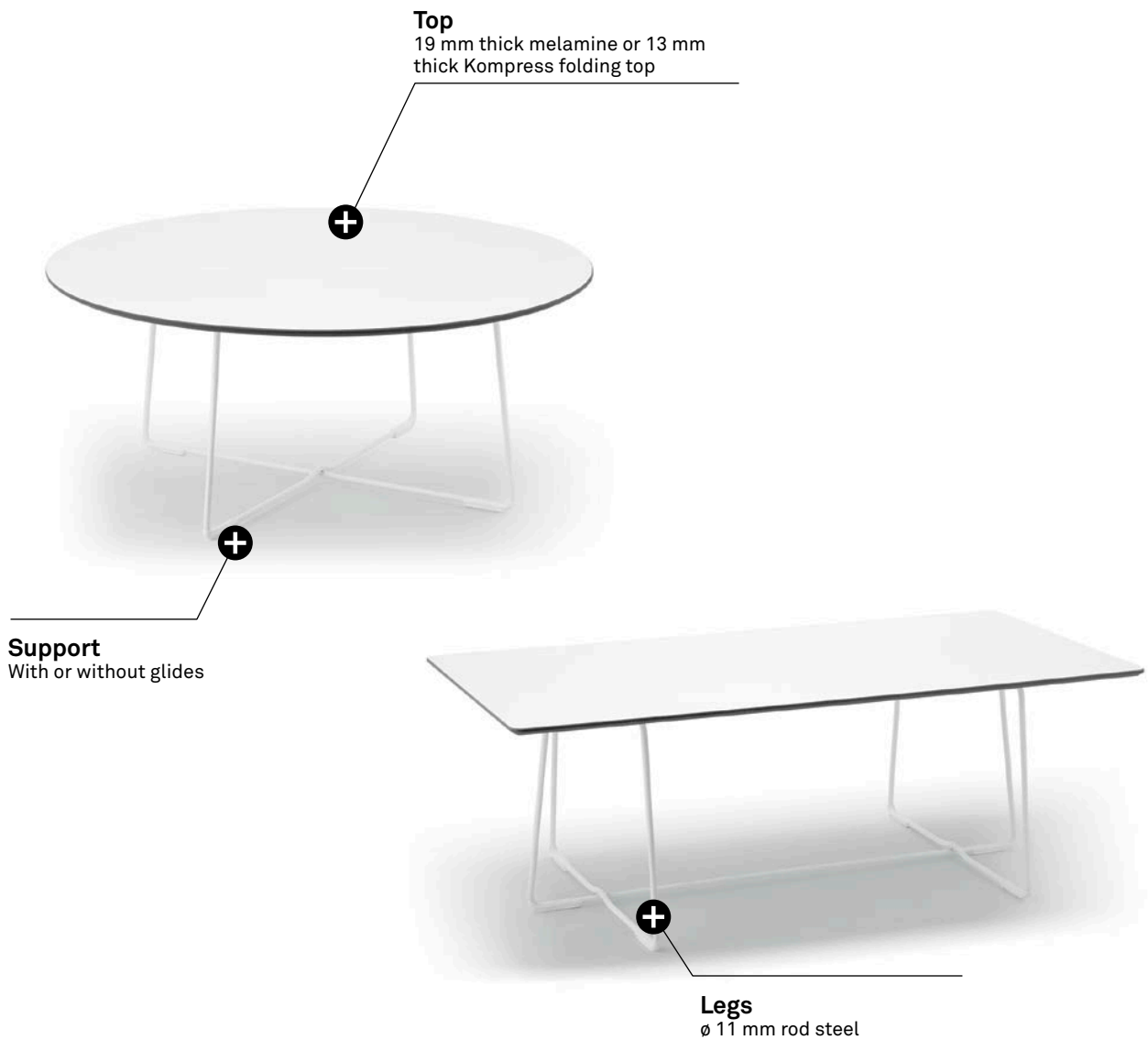

DIMENSIONS

TABLES	Round Ø 100	Round Ø 80	Square 60x60	Rectangular 120x60
Height (melamine / kompres)	42,4 - 41,8 cm	42,4 - 41,8 cm	42,4 - 41,8 cm	42,4 - 41,8 cm
Diameter or width	100 cm	80 cm	60 cm	120 cm
Depth			60 cm	60 cm
Weight (melamine/kompres)	16,1-16,8 kg	12,5 - 12-7 kg	10,4 - 10,7 kg	17,5 - 18 kg

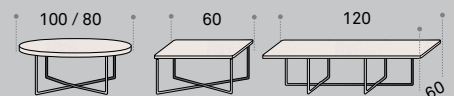

SEAT MODULES

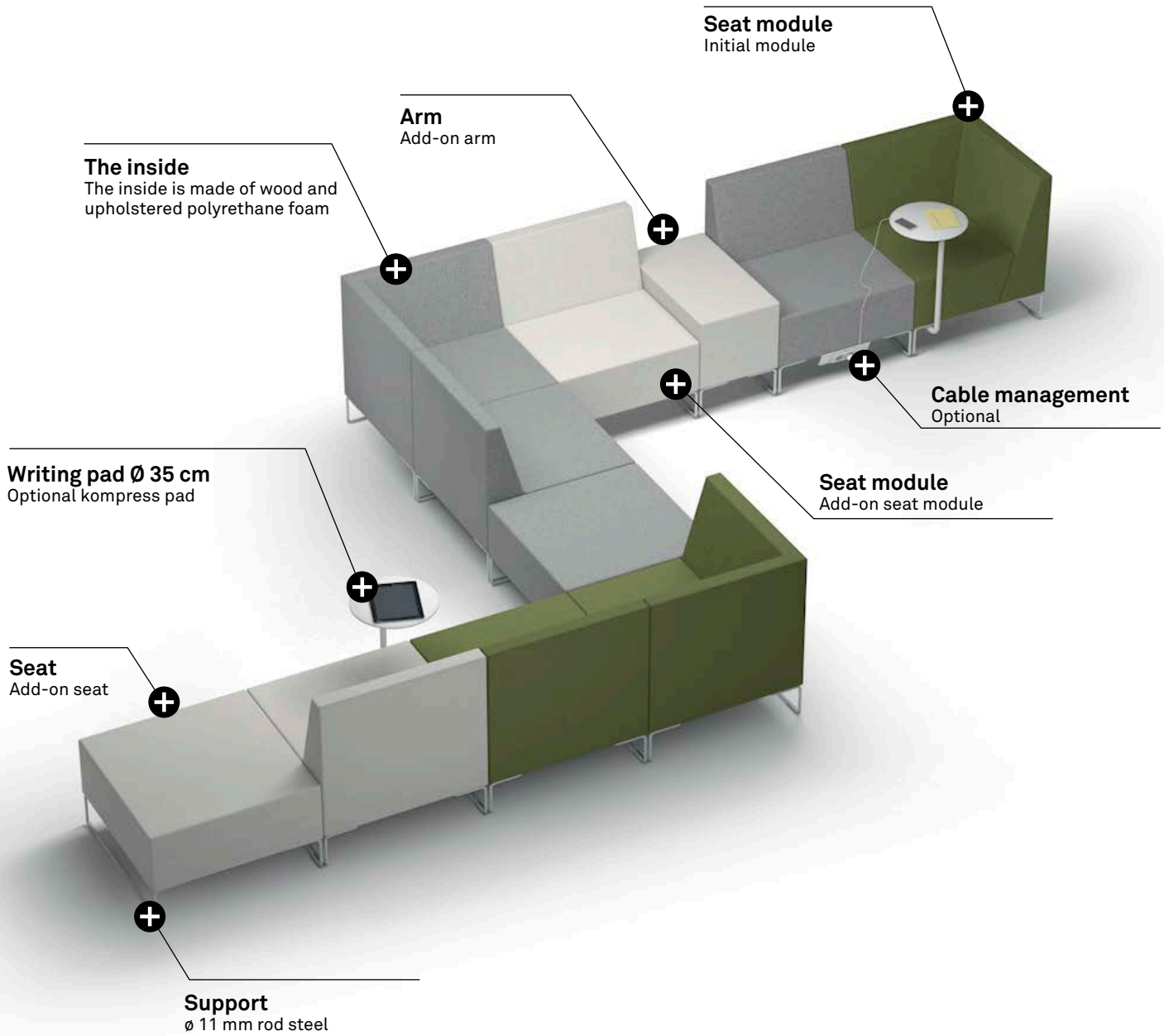

DIMENSIONS

SEAT MODULES	Initial	Add-on	Add-on seat	Arm
Height	76,5 cm	76,5 cm	40,5 cm	49,5 cm
Width	70 cm	70 cm	70 cm	40 cm
Depth	70 cm	70 cm	70 cm	70 cm
Fabric meter lineals	2,85 cm	2,35 cm	1,4 cm	1,2 cm
Weight	29,4 kg	22,05 kg	15,43 kg	14,81 kg

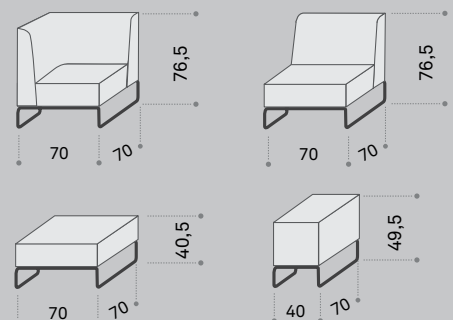

STOOLS

SEAT: structural base made of particle board 18 mm thick and equipped with injected nuts and polyurethane foam 65 kg/m³ 42 mm thick, all upholstery and subsequently attached to the rod structure by injection flanges of polyamide with fiber glass. Available in two diameters of 373 and 544 mm, and three heights of structures.



MESAS DE CENTRO

MELAMINE TOPS: 19 mm thick particle board. 2 mm thick thermofused edges around the perimeter. Drilled underneath to allow the assembly. The quality requirements for the board are made according to the UNE-EN 312 legal terms, corresponding to P2 board. The average 19 mm thick board density is 630 kg/m³.

KOMPRESS TOPS: 13 mm thick board top, high density fiber resistant to humidity with melamine coating on the top and bottom faces. Machined at the bottom for its correct assembly. Unclad edge, black finish.



SEAT MODULES

Structure made of solid wood combined with particle board and fibers, suitably stuck and screwed for its correct functioning. Later, it is added elastic bands and it is covered with a range of different hardness polyurethane foams with high density and finally it is upholstered. The seat modules on a fixed support made of Ø 11 mm calibrated rod and covered with epoxy paint.

The seat modules are configurable and they can be assembled together with pieces, that once placed in the seat structure, they allow to change the seat disposition without tools.



UPHOLSTERY FOR STOOLS AND SEAT MODULES

The upholstery is available for the Groups 1, 2, 3 and 5 fabrics of Forma 5, including a wide range of fabrics (yarn, fireproof fabrics) and leathers. Stools can be upholstered in Nappel Pro (Group 4) Consult fabrics brochure and Forma 5 Pricelist. The Group 1, 2, 3 and 5 fabrics of Forma 5 are supplied by the manufacturer company Camira. Although our fabrics brochure includes a selection of the Camira fabrics, if the customer requires another specific, Forma 5 will upholster any of its fabrics in any fabric from Camira catalog.

STRUCTURE (STOOLS, SEAT MODULES AND TABLES)

Fixed structure made of solid steel rod \varnothing 11 mm epoxy painted 100 microns thick. The structure makes a cross in the base, with two support options depending on the type of floor: with or without carpet. The colour available is polar white or matt black.



FLOOR SUPPORT

Two options for floor support:



With glides



Without glides
for carpet

CABLE MANAGEMENT OF SEAT MODULES

As specific element of the program, Let's offers a support with an installed and adaptable schucko to any configuration of independent seats or seat modules. The schucko support, made of steel sheet with 2 mm thickness and later lacquered with epoxy paint, it is positional on any module except the arm with independent structure, always fixed to the framework in its lower part. The schuckos incorporate two power sockets and it is available with the international system or with the UK system.



WRITING PAD

Round writing pad \varnothing 350 mm, 13 mm thick board top, high density fiber resistant to humidity with melamine coating on the top and bottom faces.

This board is fixed to a steel tube of 25 x 2.5 mm screwed to the bottom of the module.



PACKING

As standard, the stools are sent assembled and with specific protections in plastic bag.

The modules are sent semi-disassembled (seat-back and structure) protected in cardboard boxes.

The tables are sent disassembled, desk top and structure with specific protections.

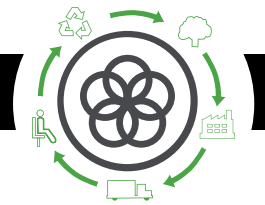

Life Cycle Analysis
LET'S SIT Program



Raw material	STOOLS		TABLES		SEAT MODULES	
	Kg	%	Kg	%	Kg	%
Steel	2,8 Kg	67,6%	2,7 kg	30,2%	5,128 kg	17,6%
Wood	1 Kg	24,2%	6,2 kg	69,4%	18,26 kg	62,7%
Plastic	0,04 Kg	1%	0,04 Kg	0,4%	0,032 kg	0,1%
Upholstered/ Filling material	0,3 kg	7,2%	—	—	5,71 kg	19,6%

% Recycled material= Stools 34%; Tables 65%; Seat modules 57%
 % Recyclable materials= Stools 92,8%; Tables 99%; Seat modules 80,4%

Ecodesign

Results reached during the life cycle stages



MATERIALS

Steel
 15%-99% recycled material.

Wood
 70% of the wood material is recycled, has PEFC/FSC and complies within the E1 standard.

Plastic
 30%-40% recycled material.

Staff material
 Without HCFC and certified by Okotext.

Upholsteries
 Without COV emissions and certified by Okotext.

Paintings
 Podwer painting without COV emissions

Packings
 100% recyclable with inks with no solvents.

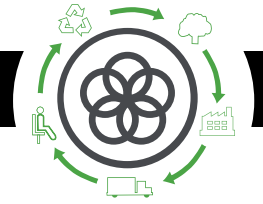

PRODUCTION

Raw materials use optimization

Board, upholstery and steel tubes cut.

Renewable energies use

reducing the CO2 emissions. (Photovoltaic pannels)

Energy saving measures

in all production process

COV global emission reduction

of the production processes by 70%.

Podwer painting

ecovery of 93% of the non deposited painting

Glue removal from the upholstery

The facilities

have an internal sewage for liquid waste.

Green points

at the factory

100% waste recycling

at production process ans dangerous waste special treatment.



TRANSPORT

Cardboard use opmitization

of the packings

Cardboard and packing materials use reduction

Flat packings and small bulks

to optimize the space.

Solid waste compacter

which reduces transport and emissions.

Light volumes and weights

Transport fleet renewal

reducing by 28% the fuel consumption.

Suppliers area reduction

Local market power and less pollution at transport.



USE

Easy maintenance and cleaning

without solvents.

Forma 5 guarantee

The highest quality

for materials to provide a 10 year average life of the product.

Useful life optimization

of the product due to a standarized and modular design.

The boards

with no E1 particle emission.



END LIFE

Easy unpacking

for the recyclability or compound reuse.

Piece standarization

for the use.

Recycled materials used for products (% recyclability):

Wood is 100% recyclable.

Steel is 100% recyclable.

Aluminium is 100% recycable.

Plastics are from 70 to 100% recyclable.

With no air or water pollution

while removing waste.

Returnable, recyclable and reusable packing

CHAIR MAINTENANCE AND CLEANING GUIDE

LINES FOR A CORRECT CHAIR CLEANING AND MAINTENANCE, CONSIDERING THE DIFFERENT MATERIALS:

FABRICS

- 1 Vacuum often
- 2 Rub the dirty spot with a wet cloth with PH neutral soap.
Test first on a hidden spot.
- 3 Dry foam for carpets can be alternatively used.

PLASTIC PIECES

Rub the dirty spots with a wet cloth with PH neutral soap.

Do not use abrasive products in any case.

METAL PIECES

- 1 Rub the dirty spots with a wet cloth with PH neutral soap.
- 2 Polished aluminium pieces can have their polish bak by covering and rubbing them with a dry cottom cloth.

LEGAL TERMS

CERTIFICATES

Forma 5 certifies that Let's program has passed all tests provided by AENOR INTERNATIONAL:

UNE-EN-ISO 14006:2011 : management system certificate of Ecodesign

Forma 5 certifies that the Let's Sit program has passed all tests provided by our intern Quality Department and the Technological Research Center (CIDEMCO) with satisfactory results:

UNE-EN 1639:2013: "Furniture - Strength, durability and safety - Requirements for non-domestic seating".

Developed by GABRIEL TEIXIDÓ